

Antenna Switching

I published an article in the August 2024 publication of Practical Wireless Magazine.

Electronic viewing of the magazine, as part of a subscription, is here: <https://pocketmags.com/eu/practical-wireless-magazine>

As necessitated by space constraints the photos in the article might be a little small to be of any use for some readers.

So here are each of the graphics and photographs in high resolution.

Samuel

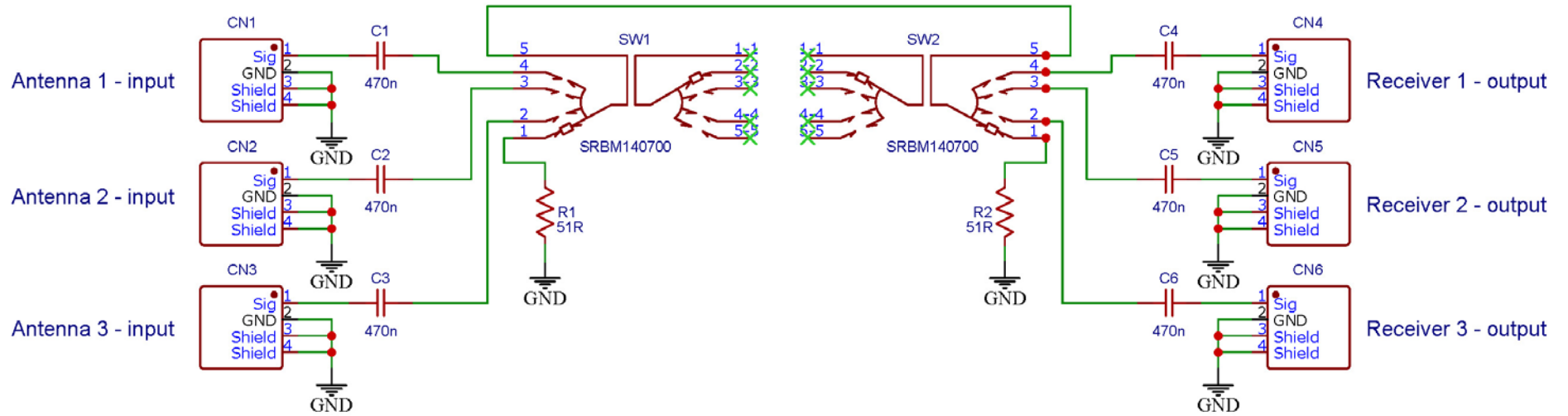

Figure 1. Schematic diagram.

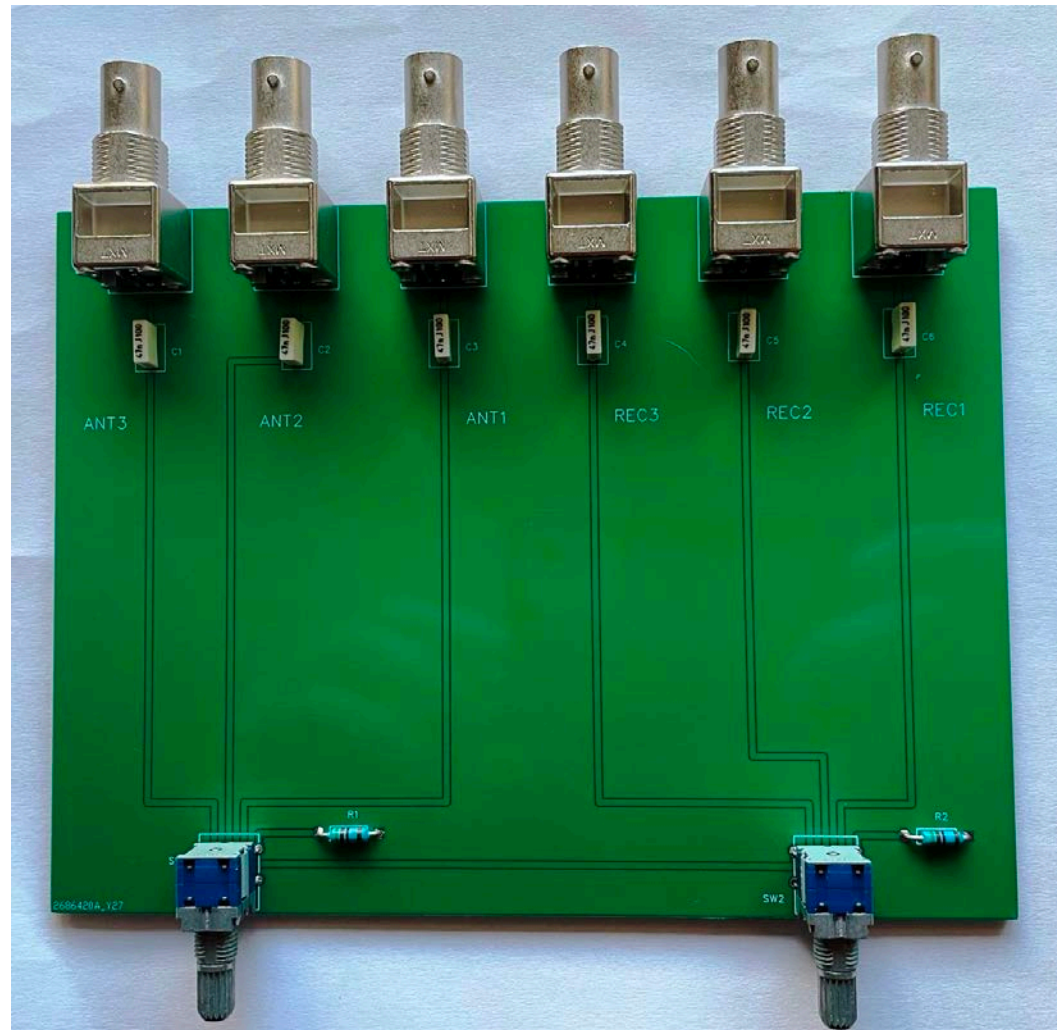

Figure 2. Top view of PCB



Figure 3. Front and back view of the enclosure

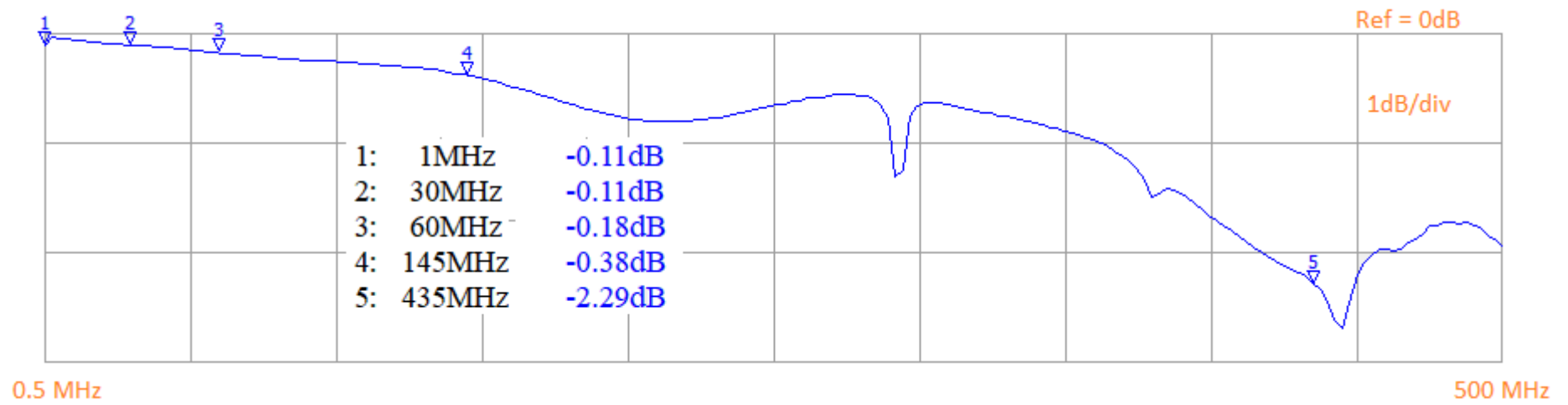

Figure 4. Transmission coefficient – S21

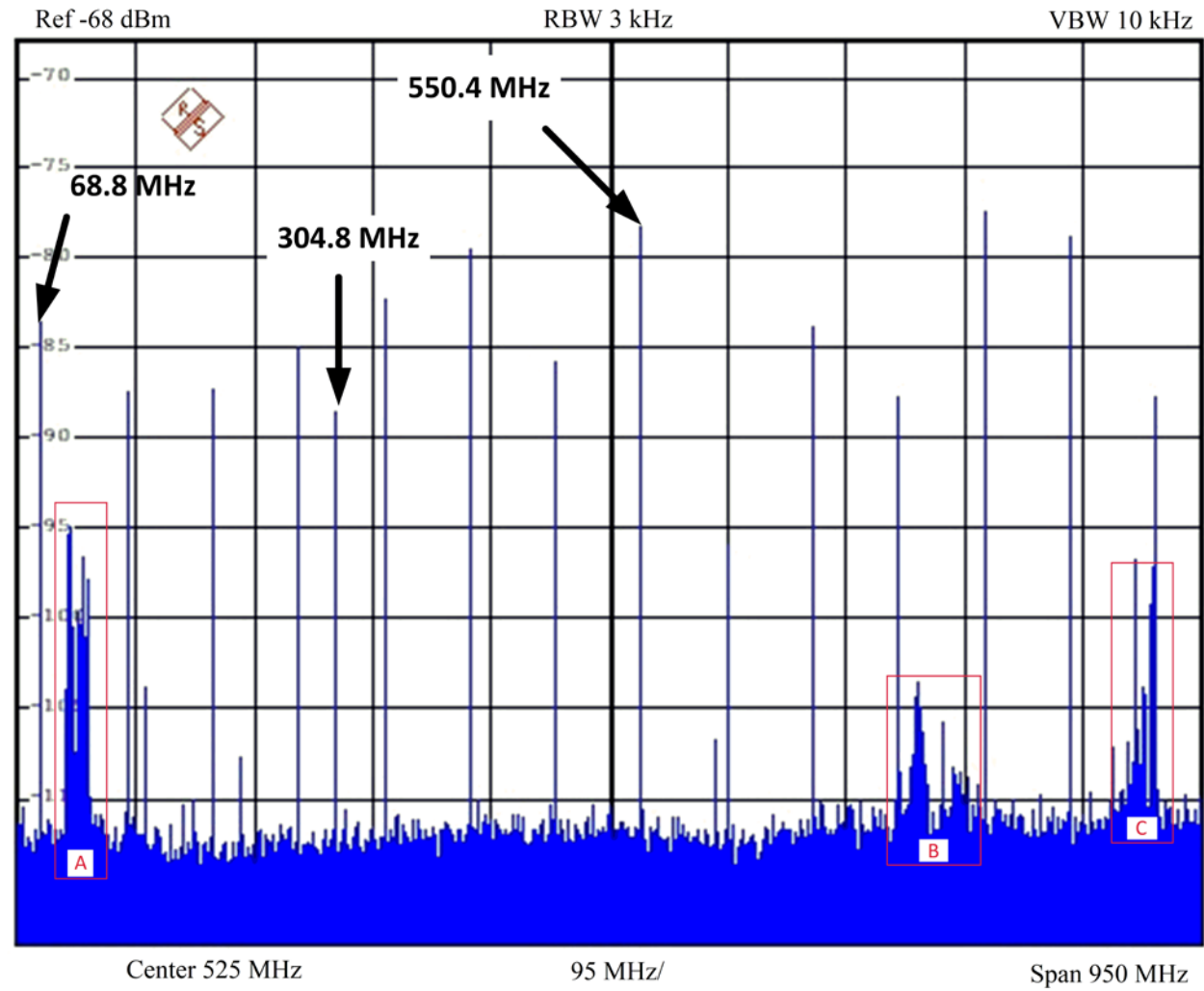

Figure 5. Coming out of the antenna port

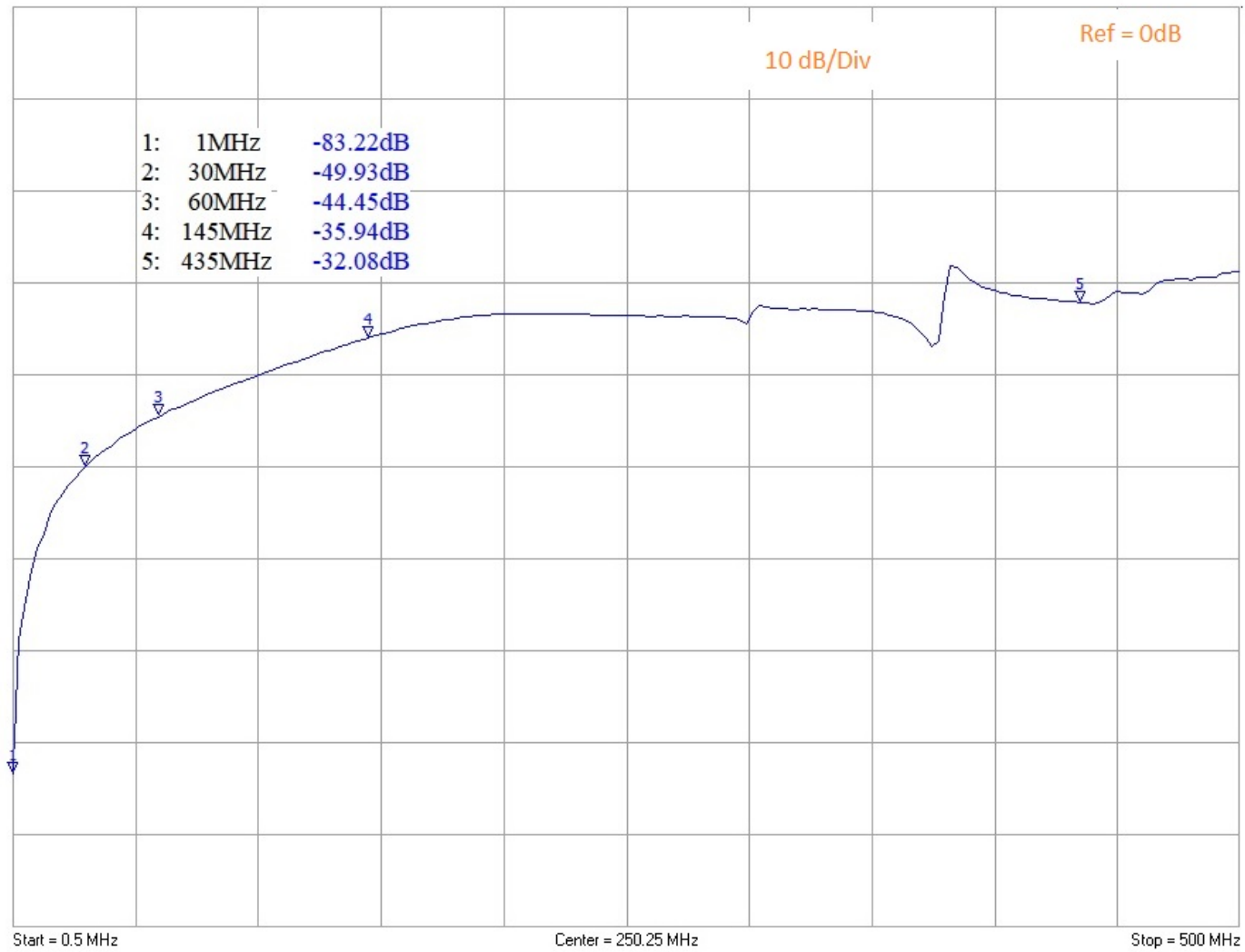

Figure 6. Isolation between receivers

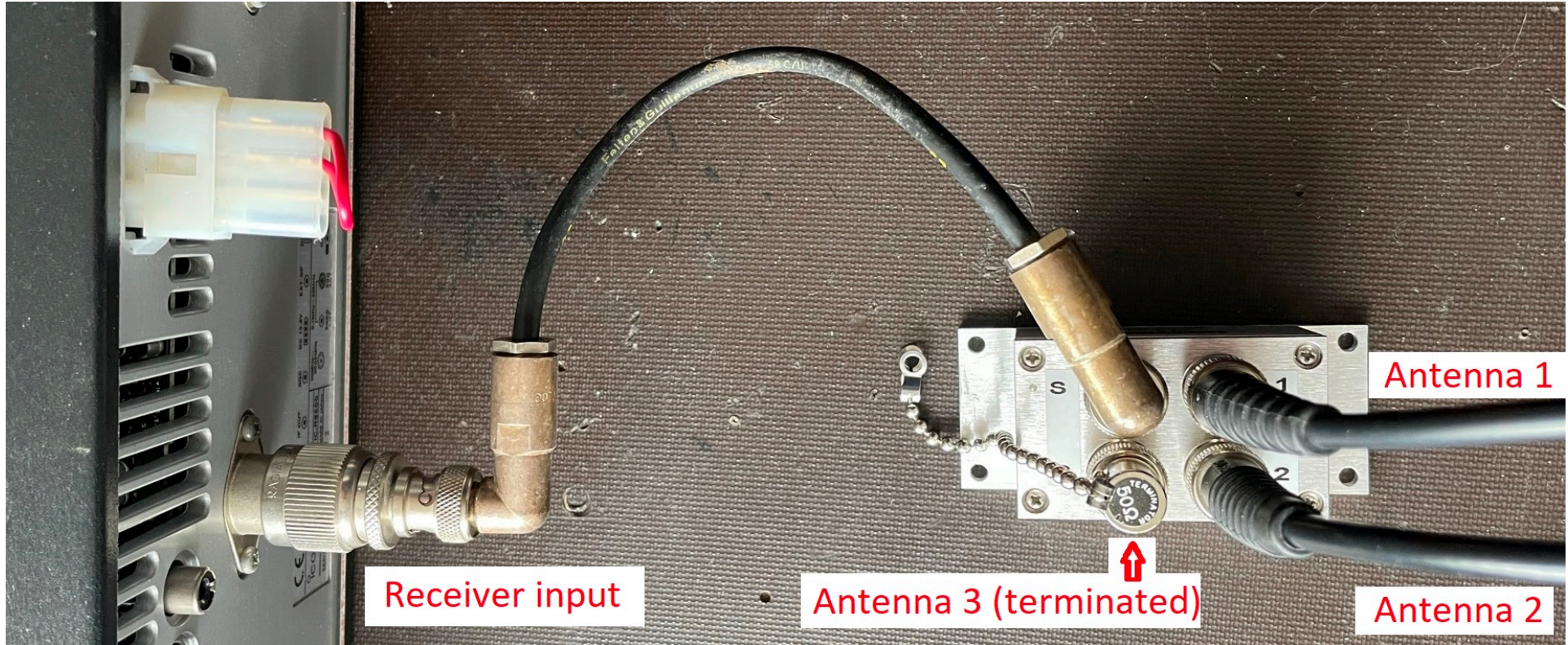

Figure 7. Using a passive combiner

Ends